

Sealed lead acid batteries

43 Ah mainship battery



Securaplane Sealed Lead Acid (SLA) mainship batteries have technology that beats NiCad, lead-calcium and lead antimony in every category of performance, ultimately saving operators thousands of dollars annually.

Securaplane is the master distributor and design and certification authority for EnerSys Hawker brand batteries for commercial and business aviation in the USA.

Hawker mainship batteries offer significant performance enhancements compared to competing products.

Key features

- 99.99% pure lead construction for enhanced life and performance.
- Batteries shipped fully charged and ready to install.
- Non-hazardous for shipping by ground and air.
- True no-maintenance with unsurpassed cranking power.
- Hot and cold performance exceeds competing products.
- Monobloc replacement significantly less than the list price of new battery.

Applications

Securaplane 43 Ah batteries are STC- and PMA-approved for installation on numerous aircraft, including:

- Beechjet 400, 400A, 400T
- Boeing 747-100, -200, -300, -SP
- Cessna Citation I, II, V, Bravo, Ultra, Encore, Encore+, 560XLS, 56XLS+
- Bombardier CRJ series
- Bombardier Q-100, -200, -300
- Dassault Falcon 2000, 2000EX
- Hawker HS125 through 900XP series
- King Air 100, 200, 300, 90 series

Securaplane

Our product competencies and services

Aircraft security systems | Airborne video cameras | Aircraft batteries | Battery chargers | Inverters | Converters | Wireless integration

© Securaplane | January 2014

MEGGITT
smart engineering for
extreme environments

Sealed lead-acid batteries

43 Ah mainship battery

Specifications

Part number

9750W0370-xx

Size

9.99 x 9.72 x 10.75 inches max

DC connector (J1)

MS18093/MS3509

Temperature sensor connector (J2)

Per application requirements

Qualification

DO-160C

Weight

91 lb (41.28 kg)

Nominal voltage

24V

Nominal capacity

43Ah

Transportation

Non-hazardous and unrestricted when securely packed and protected against short circuit.

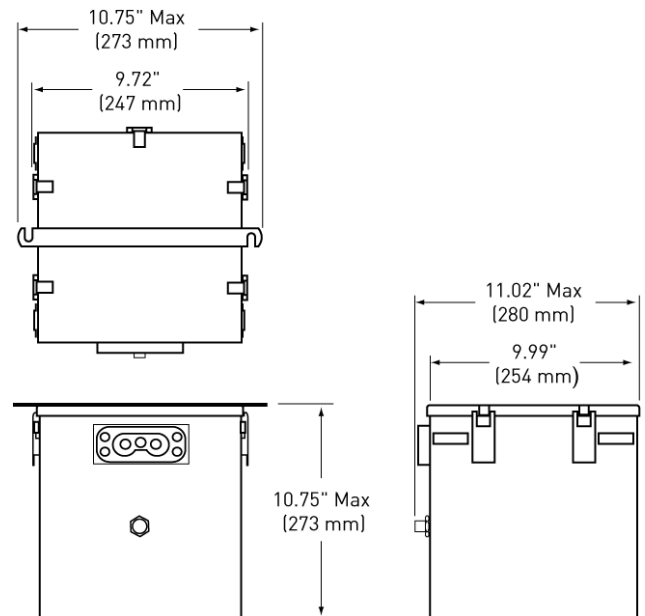

Specification subject to change.
Images for illustration only.
Please contact Securaplane for installation data

Performance

Storage of uncommissioned product

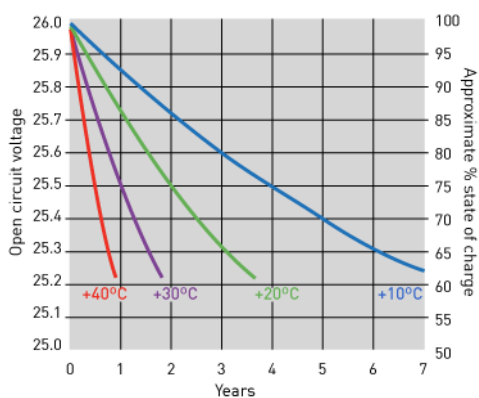

Charge recovery rate vs charge voltage

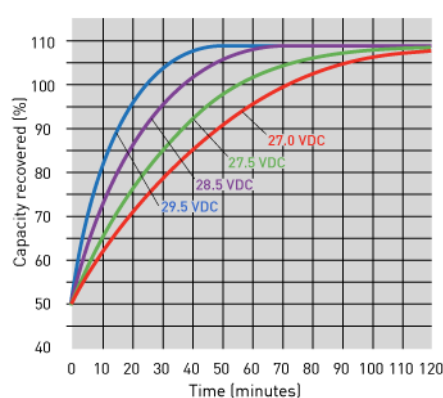

Power rating

Testing of Group B sample to Batspec 210 clause of 3.9 and IEC 952-1 clause 6
Test Reference PDTR 1817 - June 1998

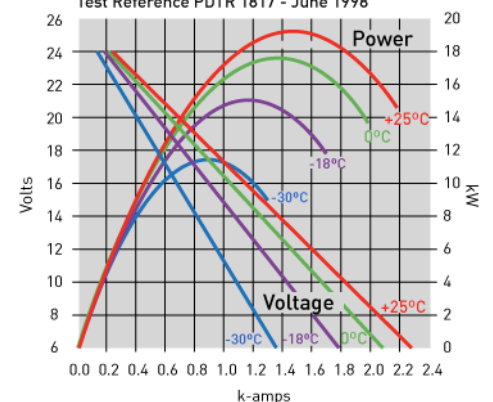

Securaplane

12350 N Vistoso Park Road
Oro Valley AZ 85755
USA

Tel: +1 (520) 297 0844
Fax: +1 (520) 498 4924

www.securaplane.com
www.meggitt.com